

MANTALL XE 100C



MANTALL XE100C SCISSOR LIFT

The XE100C is pollution free like the rest of the XE-series from Mantall, that is why it is ideal to use indoors at a production line and it is equipped with non marking tires so it doesn't damage any delicate floors. The electric scissor lift have a powerful traction so the XE100C climb ramps easily.

The XE100C from Mantall can both be operated from the platform and the ground. It has a working height of 10 m which it can reach in 45 sec. The platform has a maximum capacity of 450 kg and an optional extension.

Key Features

- Manual emergency lower system
- Platform swing gate
- Extended platform
- Foldable platform
- Multi-disc wet brake
- Manual brake release
- Pothole protection
- Non-marking tires
- AC power to platform
- Tilt alarm
- Buzzer
- Safety brackets
- Charging indicator
- Forklift pockets
- Diagnosis system
- Maintenance free battery
- Dual flashing beacon

10m

Working Height

Technical Specifications

Working height max(m)	10
Platform height max(m)	8
Outreach(m)	1
Lifting capacity(kg)	230
Lifting capacity(kg)(Extended platform)	120
Weight(kg)ANSI/CSA Standard	1855
CE/AUS Standard	2000
Platform size(L×W×H)m	2.25 x 0.8 x 1.1
The length of platform extended(m)	3.2
Skirting board height(m)	0.15
Stowed size(L×W)m	2.42 x 0.8
Stowed height(m)	2.3
Length of the machine with platform extended(m)	3.4
Height of the machine with platform folded (m)	1.86
Hydraulic tank capacity(L)	15
Gradeability	25%
Wheelbase(m)	1.85
Ground clearance(m)	0.1
Pothole protection board ground clearance(m)(down)	0.019
Inside rotation radius(m)	0
Outside turning radius(m)	2.12
Load number max	2
Raised time/Lowering time(s)	35/17
Traction speed(km/h)	3.4
Safe speed(km/h)	0.7
Vertical tilt°	3
Lateral tilt°	2
Power source	4x6V:225Ah
Tire size(mm)	356 x 114 x 254
Drive model	"Hydraulic drive/Electric drive"

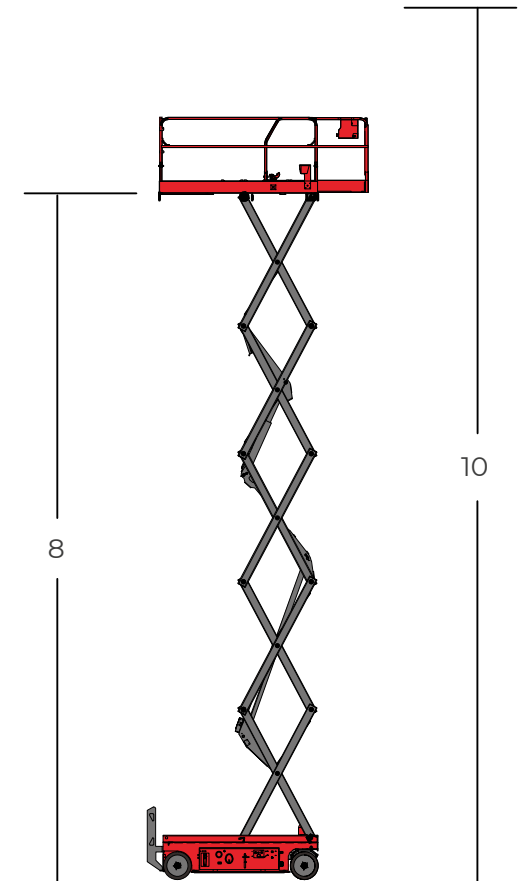

TECHNICAL DATA (M)

