

# StoneVac GSK200

**300kg**  
Safe Working Load

## One of our bestselling stone vacuum lifters

The Stone Vac GSK200 can easily lift stone panels, blocks, bricks, paving slabs and kerbs weighing up to 300kg.

Capable of lifting stone in both vertical and horizontal positions, the Stone Vac GSK200 features a constant running vacuum system to lift different stone types including porous limestone, as well as polished granite and marble.

This below-the-hook stone vacuum lifter is powered by a rechargeable battery so there are no tricky cords to deal with during operation.



### Technical Data (mm)

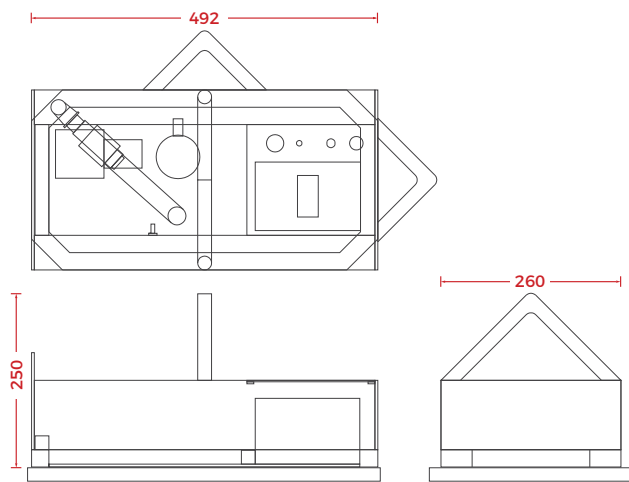

Optional radio remote control

### Key Features

- Capacity: 100-300kg (depending on pad options)
- Dimensions: 492mm (l) x 260mm (d) x 250mm (h)
- Constant running single circuit vacuum system
- 12v battery with 240V charger
- Audio-visual low vacuum warning
- Weight: 32kg (with standard pad)
- Optional radio remote control
- Standard 300kg: pad size 500mm (l) x 300mm (w) (vertical 200kg only)
- Optional 150kg: pad size: 800mm (l) x 120mm (w) (vertical 100kg only)

