

StoneVac GSK1000

1000kg
Safe Working Load

Proven results

This popular 1000kg capacity stone vacuum lifter has proven results in the construction, rail, stone masonry and infrastructure sectors amongst others.

Designed for horizontal lifting of both porous and polished stone, the Stone Lifter GSK1000 has a constant running vacuum system and closed cell foam ring pad that is flexible enough to work with irregular or textured stone surfaces.

This below-the-hook stone lifter includes a range of pads with lifting capacities from 90kg to 1000kg depending on the shape and size of the load.



Technical Data (mm)

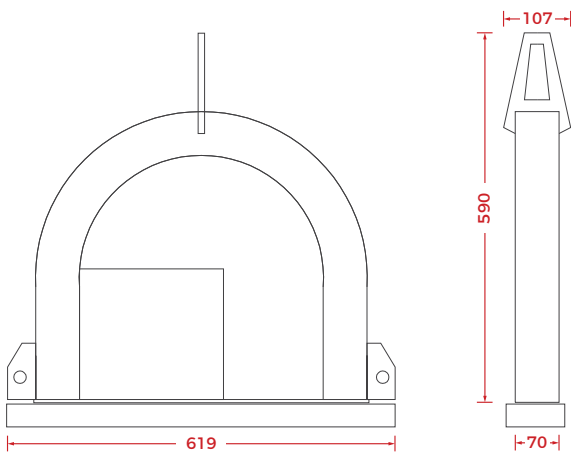

Optional radio remote control

N.B: Capacities reduced for vertical lifting, please contact our technical team for further information.

Key Features

- Capacity: 90-1000kg (depending on pad options)
- Dimensions: 619mm (l) x 107mm (d) x 590mm (h)
- Constant running single circuit vacuum system
- 12v battery with 240V charger
- Audio-visual low vacuum warning
- Weight: 44kg (with standard pad)
- Standard 1000kg: pad size 1000mm (l) x 450mm (w)
- Optional 500kg: pad size 900mm (l) x 250mm (w)
- Optional 300kg: pad size 600mm (l) x 250mm (w)
- Optional 90kg: pad size 700mm (l) x 120mm (w)



VACUUM LIFTERS