

Hydraulica 2600

Quad-Circuit Compact

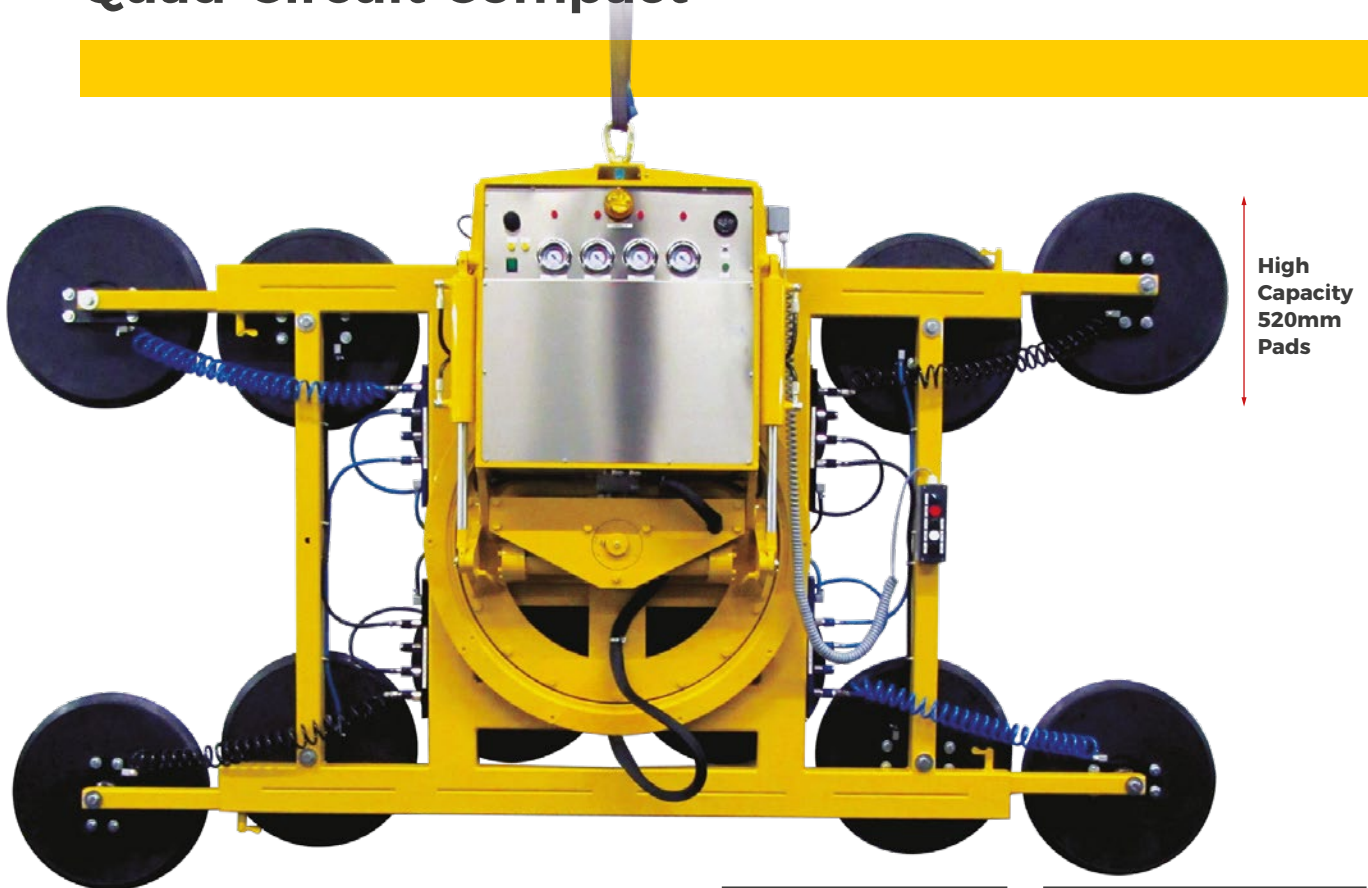

Quad-Circuit Heavy-Duty Lifting Power

Bringing the latest in modern vacuum lifting technology to the market, the Hydraulica 2600 Quad-Circuit Compact boasts four independent vacuum circuits for quicker, safer and more efficient lifting performance on site.

Retaining all the benefits of our standard Hydraulica 2500 lifter, the innovative Hydraulica Quad-Circuit also has a more compact frame for lifting glass under tricky soffits and overhangs, as well as larger 520mm vacuum pads to achieve quicker vacuum suction.

Features 210° powered rotation and 90° hydraulic tilt for easy control of heavy loads.



Control panel with quad-circuit vacuum and 90° twin hydraulic tilt cylinder system



Wheeled stand as standard



High Capacity Pads



Remote Controls

Key Features

- Capacity: 2600kg
- Four vacuum circuits with 4 on-board maintenance free vacuum pumps
- Powered 210° lockable rotation
- 90° hydraulic tilting
- Audio-visual low vacuum alert
- 12v rechargeable battery with integral 110v or 240v charger and battery energy gauge
- Wheeled stand for transport and storage available
- Cable remote control as standard, optional radio remote
- Individual pads can be isolated for irregular units
- Sliding extension arms

2600kg

Safe Working Load



Technical Specifications

Safe working load (smooth, clean surface at 60% vacuum)	capacity:	2600kg*	1850kg
Number of suction cups	cups:	12	8
Suction cup	description:	black rubber, not abrasion resistant.	
Suction cup diameter	diameter:	520mm	
Suitable for lifting	material properties:	gastight / non-porous	
	surface:	smooth	
	example:	glass, plastic boards, ceramic plates, sheet metals, coated boards	
Weight of lifter	approx:	640kg (with 12 pads)	
Depth of lifter	depth:	385mm	
Rotation	rotation:	105° left & right powered hydraulic	
Tilt	tilt:	90° powered hydraulic	
Vacuum system	dual circuit:	4 pumps, 4 vacuum reserve tanks	
Voltage	pump:	12v DC from rechargeable batteries	
	battery charger:	110v/240v 50/60Hz single phase factory selectable	
Standard accessories	standard	cable remote control, extension arms, wheeled stand	

* The capacity is 2600kg with extension arms and 12 pads fitted.

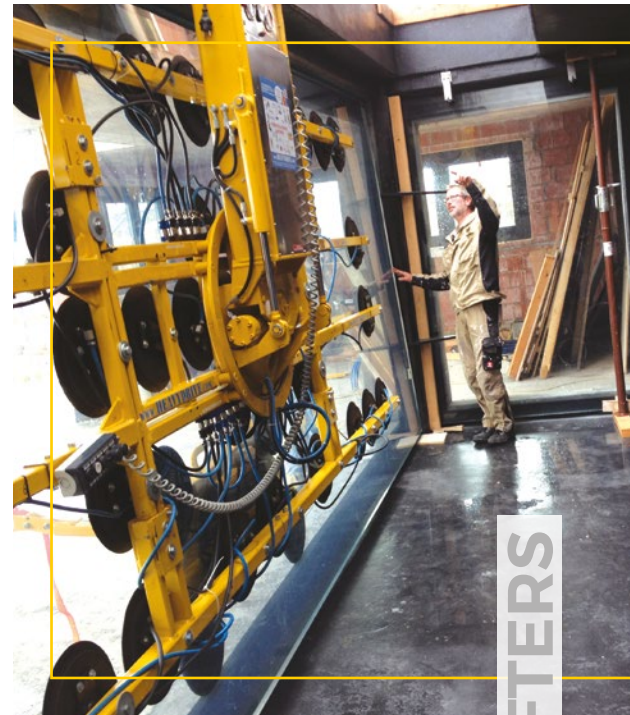

Technical Data (mm)

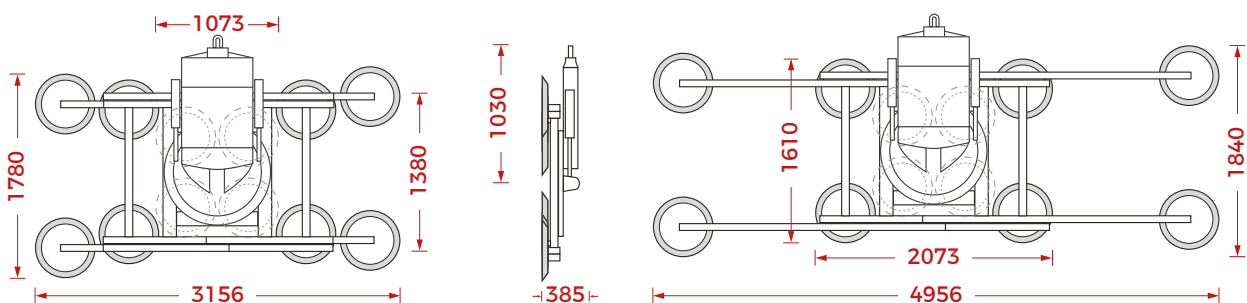

VACUUM LIFTERS