

MANTALL XE 120W



MANTALL XE120W SCISSOR LIFT

Mantall® XE120W Scissor Lift has a maximum working height of 12 meters and a maximum load capacity of 400 kg. With an overall width of 1.2 meters, XE120W has a larger working platform and can carry 2 people and more materials or tools. It has pothole protection, a proportional joystick and better stability. XE120W Scissor Lift is battery powered, low noise, emission free and suitable for indoor maintenance or outdoor tasks.

Key Features

- Manual emergency lower system
- Platform swing gate
- Extended platform
- Foldable platform
- Multi-disc wet brake
- Manual brake release
- Pothole protection
- Non-marking tires
- AC power to platform
- Tilt alarm
- Buzzer
- Safety brackets
- Charging indicator
- Forklift pockets
- Diagnosis system
- Maintenance free battery
- Dual flashing beacon

12m

Working Height

Technical Specifications

Working height max(m)	12
Platform height max(m)	10
Outreach(m)	1
Lifting capacity(kg)	350
Lifting capacity(kg)(Extended platform)	120
Weight(kg)ANSI/CSA Standard	2370
CE/AUS Standard	2810
Platform size(L×W×H)m	2.3 x 1.15 x 1.1
The length of platform extended(m)	3.3
Skirting board height(m)	0.176
Stowed size(L×W)m	2.42 x 1.2
Stowed height(m)	2.38
Length of the machine with platform extended(m)	3.42
Width of the machine with platform folded (m)	1.9
Hydraulic tank capacity(L)	25
Gradeability	25%
Wheelbase(m)	1.85
Ground clearance(m)	0.1
Pothole protection board ground clearance(m)(down)	0.019
Inside rotation radius(m)	0
Outside turning radius(m)	2.3
Load number max	3
Raised time/Lowering time(s)	65/52
Traction speed(km/h)	3.4
Safe speed(km/h)	0.7
Vertical tilt°	3
Lateral tilt°	2
Power source	4x6V.225Ah
Tire size(mm)	406 x 127 x 318
Drive model	"Hydraulic drive/Electric drive"

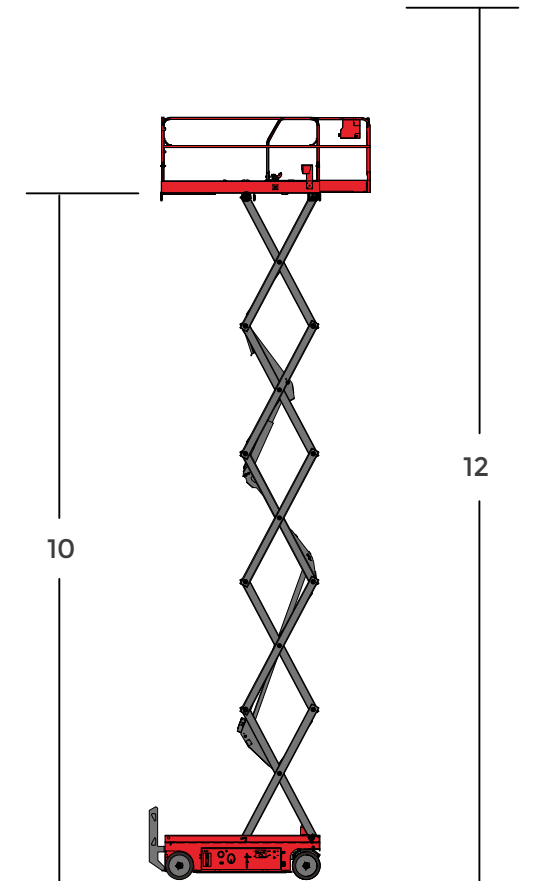

TECHNICAL DATA (M)

